

The effect of added surface active agents was unexpected. It was anticipated that such active material would be preferentially adsorbed and block adsorption sites leading to a reduced reaction rate, but this was contrary to the observed facts. The mercury droplets produced in these reactions were extremely small; *i.e.*, the surface area (and reaction rate) was increased masking any effect due to the blocking of adsorption centers. Smaller droplets could be ascribed to a strongly held film of the surface active material preventing coalescence. Quantitative interpretation must depend on measurement of surface area involved, preferably using a series of compounds and conditions. A later report on kinetic data for such a series will include the quantitative interpretation of surface area measurements.

Only preliminary observations on the reaction mechanism may be made at this stage. Neither ionic nor free radical mechanisms appear to be involved, as mercury aryl free radicals have only been observed under exceptional conditions.<sup>37</sup> Chromatographic evidence points to a transition state similar to that proposed by Reutov, *i.e.*

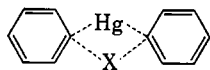

where X is some species of mercury atom, the nature of

(37) J. Kraus, *J. Am. Chem. Soc.*, **35**, 1732 (1913).

which is the subject of future work. Five steps in the reaction process are envisaged: (1) transport of the reactants to the surface, (2) adsorption of reactants on to the surface, (3) reaction at the surface, (4) desorption of the products from the surface, and (5) transport of the reactants from the surface.

Steps 1 and 5 would be rate controlling in a diffusion-controlled reaction. In the absence of solvent effects, steps 2 and 4 should require the same activation energy, but anomalous concentration effects suggest that this is not so. It would be expected that the reactants should be solvated, and the products, at least initially, not. Solvation of the arylmercury atom tends to produce an angled  $sp^3$  configuration from the linear  $sp$  type. It must be presumed that the linear structure would be the more strongly adsorbed, leading to the observed inhibition of reaction product. If this theory is correct, then change of solvent should produce little change of reaction rate but change the shape of Figure 4. Also the effect of varying benzene ring substituents should produce a change of rate. In particular, *ortho* substituents might be expected sterically to influence the transition state, and *para* substituents to inhibit the adsorbability of the reactants in the angled structure. These effects may be treated by the Hammett and Leffler relationships and form the subject of the next contribution.

*Acknowledgment.* For D. R. P. a maintenance grant for this work was provided by the Sir John Cass College.

## A $P^{31}$ Nuclear Magnetic Resonance Study of Complexing between $Li^+$ , $Ca^{2+}$ , and $Mg^{2+}$ Ions and the Lower Condensed Phosphate Polyanions<sup>1</sup>

M. M. Crutchfield and R. R. Irani

*Contribution from the Monsanto Company, Inorganic Chemicals Division, Research Department, St. Louis, Missouri 63166. Received February 17, 1965*

*High resolution 24.3-Mc.  $P^{31}$  nuclear magnetic resonance spectra of the aqueous tetramethylammonium salts of several condensed phosphate polyanions—pyrophosphate, tripolyphosphate, trimetaphosphate, and tetrametaphosphate—have been studied as a function of added  $Li^+$ ,  $Mg^{2+}$ , and  $Ca^{2+}$  chlorides. Complex formation between the added cations and the phosphate anions produces observable changes in the phosphorus chemical shifts and spin coupling constants. The data give information about the stoichiometry, relative strength, mean lifetime, and dynamic structural geometry of the complexes. The concept of specific site binding is discussed in terms of a simple electrostatic model.*

### Introduction

The tendency for strong complex formation in aqueous solution between alkali or alkaline earth

(1) A portion of this paper was presented before the Division of Inorganic Chemistry, 145th National Meeting of the American Chemical Society, New York, N. Y., Sept. 1963.

metal ions and the lower condensed phosphates, particularly pyrophosphate,  $P_2O_7^{4-}$ , and tripolyphosphate,  $P_3O_{10}^{5-}$ , is well known.<sup>1-6</sup> Most studies of these complexes have been concerned with quantitative determinations of their stability constants or with their stoichiometric formulas. There has been considerable speculation as to the nature of the bonding in such complexes, *i.e.*, whether partly covalent or totally ionic in character, and, if ionic, whether or not the cations are bound at specific sites of the polyanion as opposed to a random, nonoriented, ionic-atmosphere type of electrostatic attraction. The physical evidence has been discussed by Van Wazer and Callis.<sup>2</sup>

Calculated Bjerrum radii of metal polyphosphate complexes have been interpreted in favor of ionic

- (2) J. R. Van Wazer and C. F. Callis, *Chem. Rev.*, **58**, 1011 (1958).  
 (3) S. M. Lambert and J. I. Watters, *J. Am. Chem. Soc.*, **79**, 5606 (1957).  
 (4) J. I. Watters and S. M. Lambert, *ibid.*, **81**, 3201 (1959).  
 (5) R. R. Irani and C. F. Callis, *J. Phys. Chem.*, **64**, 1398 (1960).  
 (6) R. R. Irani, *ibid.*, **65**, 1463 (1961).

bonding.<sup>2,5</sup> However, the Bjerrum model<sup>7</sup> assumes the anion is a rigid sphere, which must be somewhat of an oversimplification, especially for the quite nonspherical tripolyphosphate anion. It has been previously suggested that a differentiation between specific site-binding and ionic-atmosphere complexing should be possible by the use of different methods of measurement which can "dig down" into the counterion atmosphere by various amounts.<sup>8</sup>

Recent observation<sup>9</sup> of the effect of changing ionic environment on the  $P^{31}$  nuclear magnetic resonance (n.m.r.) signals of condensed phosphate ions suggested n.m.r. as a possible exploratory tool for the reinvestigation of the site-binding question. The phosphorus nuclei of the complexing anions themselves might, in effect, serve as magnetic probes for the detection of ion binding. Several n.m.r. studies of complex formation by  $H^{1-}$  and  $F^{19-}$ -containing ions have been reported,<sup>10</sup> and complexing by adenosine triphosphate has been studied by Cohn and Hughes<sup>11</sup> using phosphorus n.m.r. Effects on  $Na^{23}$  spectra due to complexing by phosphates have also been observed.<sup>12</sup>

We had previously observed an abrupt change in the magnitude of the phosphorus-phosphorus spin coupling constant for the tripolyphosphate ion in increasingly basic solution and had interpreted this as resulting from the effect of  $Na^+$  ion complexing.<sup>9</sup> It seemed worthwhile to make a more detailed study of  $P^{31}$  n.m.r. spectra of several condensed phosphate anions as a function of added metal ions to determine what additional insight into the metal-phosphate interaction might be obtained. The alkaline earth metal ions,  $Ca^{2+}$  and  $Mg^{2+}$ , were studied, as well as  $Li^+$ , the most strongly complexed of the alkali metal ions.

## Experimental

**N.m.r. Measurements.** The 24.3-Mc. n.m.r. spectrometer and measurement techniques were the same as those previously described.<sup>9</sup> Chemical shifts are reported relative to 75%  $H_3PO_4$  as an external reference contained in a 1-mm. capillary inserted in the 5-mm. o.d. precision, nonspinning sample tube. Use of 75%  $H_3PO_4$  rather than the conventional 85% acid was found to give a sharper reference peak with no detectable change in chemical shift and only negligible decrease in reference signal intensity. Upfield shifts are considered positive. All measurements were made at 25°. For adequate signal-to-noise ratios, it was necessary to limit measurements to relatively concentrated solutions (0.1 to 0.5 *M*).

N.m.r. data are reported as obtained, with no extrapolations to infinite dilution or corrections for bulk susceptibility differences being used. Check experiments with pyrophosphate showed a small concentration dependence of the  $P^{31}$  chemical shift amounting to  $-21$  c.p.s. l. mole<sup>-1</sup>, which is much smaller than the effects due to complexing, which were being studied.

(7) H. S. Harned and B. B. Owen, "The Physical Chemistry of Electrolytic Solutions," Reinhold Publishing Corp., New York, N. Y., 1950, p. 42.

(8) J. R. Van Wazer, *J. Phys. Chem.*, **58**, 739 (1954).

(9) M. M. Crutchfield, C. F. Callis, R. R. Irani, and G. C. Roth, *Inorg. Chem.*, **1**, 813 (1962).

(10) (a) L. E. Erickson and R. A. Alberty, *J. Phys. Chem.*, **66**, 1702 (1962), and references contained therein; (b) R. J. Kula, D. T. Sawyer, S. I. Chan, and C. M. Finley, *J. Am. Chem. Soc.*, **85**, 2930 (1963).

(11) M. Cohn and T. R. Hughes, Jr., *J. Biol. Chem.*, **237**, 176 (1962).

(12) O. Jardetsky and J. E. Wertz, *J. Am. Chem. Soc.*, **82**, 318 (1960).

Chemical shifts were generally measured with a reproducibility of  $\pm 1$  c.p.s. or  $\pm 0.04$  p.p.m., while spin couplings were reproducible to within  $\pm 0.2$  c.p.s.

**Chemicals.** Condensed phosphates were Monsanto laboratory samples of high purity.<sup>5</sup> The solid sodium salts were converted to aqueous stock solutions of their tetramethylammonium salts by ion exchange using Dowex 50W-X4, 20-50 mesh resin on a 1-m. column. It was assumed that the large tetramethylammonium ions would not interfere significantly in the complexing studies. Subsequent studies described elsewhere in this paper indicated that this is only approximately valid. The alkali and alkaline earth metal ions were added as standardized solutions of their chlorides. All other chemicals were reagent grade or best grade available.

**Complexing Studies.** Studies of metal ion complexing were carried out as follows. Precisely measured volumes of standardized tetramethylammonium polyphosphate stock solutions of twice the final desired concentration were transferred to a series of precision 5-mm. o.d. n.m.r. sample tubes. Calculated volumes of water and standardized metal chloride solution were then added to the n.m.r. tubes by means of a calibrated microsyringe to obtain a series of solutions with mole ratios of metal ion to phosphate anion ranging from 0 to 2.00 in increments of 0.1 or 0.2. A simultaneous constant dilution of the original solution was maintained in each case to keep the total phosphate concentration in a given series constant. The final concentration of polyphosphate in each series (0.1 to 0.5 *M*) was kept as low as possible to minimize solubility problems while still giving n.m.r. signals with at least a 3 to 1 signal-to-noise ratio. The dilution technique was sufficient to ensure a precision of  $\pm(1$  to 2)% in the mole ratios.

The tubes were closed with polyethylene caps and the contents thoroughly mixed on an oscillating vortex mixer until the gel-like precipitates which formed initially in the region of mixing had redissolved. Complete dissolution of all solid precipitate at the higher metal ion concentrations could not always be achieved owing to solubility limitations. It was possible, however, to supersaturate some solutions up to mole ratios of 1.80 or higher and n.m.r. measurements were then made quickly before an irreversible precipitation occurred. Only measurements which were made on visually clear, homogeneous solutions in the absence of excess solid precipitate were considered. If precipitation occurred during measurement, the results were discarded.

The pH of the chain phosphate solutions was adjusted initially with tetramethylammonium hydroxide to pH 10 to 11 to ensure that the phosphates existed predominantly as free  $P_3O_{10}^{5-}$  and  $P_2O_7^{4-}$  anions, respectively. No attempt was made to control pH upon addition of metal ions, even though complexing produces a pH lowering effect. Check experiments showed that the pH lowering which occurred did not take the pH below 9.5 and the effect this produced on the chemical shifts was small compared to the effect of the metal complexing.

## Results

**A. Tripolyphosphate Chemical Shifts.** Owing to the greater information content of the tripolyphosphate

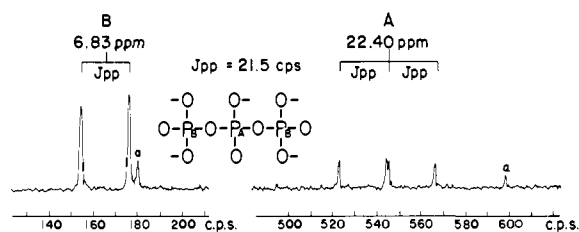

Figure 1.  $P^{31}$  n.m.r. spectrum (24.3 Mc.) of  $P_3O_{10}^{5-}$  under high resolution. Small peaks, a, are impurities.

spectrum, which contains multiplet structure due to  $P^{31}$  spin coupling between nonidentical phosphorus nuclei, it was studied in somewhat greater detail than the other anions which give only single resonance peaks.

The  $P^{31}$  n.m.r. spectrum of the tripolyphosphate ion,  $P_3O_{10}^{5-}$ , gives a typical  $AB_2$  pattern<sup>13</sup> which has been previously observed.<sup>14</sup> A spectrum of this anion under higher resolution than previously reported is shown in Figure 1, where a second-order 0.8-c.p.s. splitting of the central peak of the triplet is just resolved. The value of the phosphorus spin coupling constant  $J_{pp}$  is small compared to the chemical shift between the end and middle phosphorus atoms so that a simple first-order analysis suffices and the chemical shifts of the end and middle phosphorus nuclei may be taken at the center of the doublet and triplet, respectively.

The changes in the tripolyphosphate spectrum with added  $Li^+$ ,  $Mg^{2+}$ , and  $Ca^{2+}$  ions are plotted in Figure 2. In every case, the chemical shift of the middle P nucleus is influenced more strongly than that for the end P nuclei. This is exactly opposite to the effects observed for the covalent binding of hydrogen ions<sup>9</sup> where the chemical shift of the end nuclei was the more strongly affected, and, moreover, the changes in shift were in the opposite direction.

The observation that peaks shift in position, but no additional peaks grow into the spectrum, is consistent with rapid exchange of the complexed metal cations among the binding anions. That is to say, the mean lifetime,  $\tau$ , of a given complex ion is short. From the maximum frequency separation between complexed and noncomplexed forms of the anion,  $\tau$  can be estimated to be shorter than an upper limit of  $10^{-2}$  sec.

The observed peak positions reflect the change in the average magnetic environment of the various P nuclei between the complexed and uncomplexed states, weighted by the mole ratio of the anion in the two forms. Extrapolations of the straight portions of the curves in Figure 2 show intersections at 1:1 metal ion to tripolyphosphate ion mole ratios, confirming the stoichiometry and the stepwise formation of 1:1 complexes. The validity of this is strikingly obvious for  $Mg^{2+}$ , which forms strong complexes. With  $Li^+$ , which forms weaker complexes, the change in slope is less abrupt but still clearly present. The abruptness of this change in slope is quantitatively related to the stability constants for the complexes and might be useful for their estimation if simpler and more accurate methods were not available.

(13) J. A. Pople, W. G. Schneider, and H. J. Bernstein, "High-Resolution Nuclear Magnetic Resonance," McGraw-Hill Book Co., Inc., New York, N. Y., 1959.

(14) C. F. Callis, J. R. Van Wazer, J. N. Shoolery, and W. A. Anderson, *J. Am. Chem. Soc.*, **79**, 2719 (1957).

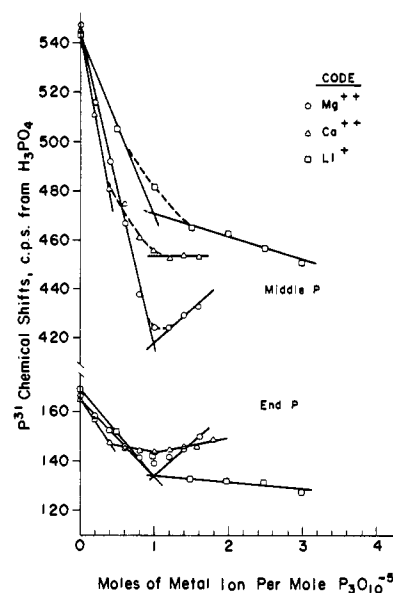

Figure 2. The effect of metal ion complexing on  $P^{31}$  chemical shifts of the tripolyphosphate anion (0.5 M) at pH  $\sim 10$ .

With  $Ca^{2+}$ , there appears to be a slight change in slope beginning gradually around an added metal ion to tripolyphosphate ratio of 0.5. This could indicate the formation of 1:2 calcium to tripolyphosphate complexes at low metal ion ratios under these conditions of high tripolyphosphate concentration. Studies by other techniques have not detected 1:2 complexes previously, but they were usually conducted at much lower over-all concentrations. The situation could be analogous to  $Cu^{2+}$ , which is reported to form 1:2 complexes with pyrophosphate at high concentrations and 1:1 complexes at lower concentrations.<sup>15</sup> The observed change in slope is not pronounced enough, however, to be considered convincing proof of 1:2 complexes since other effects may be involved, as will be discussed for pyrophosphate.

Lambert and Watters<sup>3</sup> have reported 2:1 metal to phosphate complexes with  $Mg^{2+}$  at low  $P_3O_{10}^{5-}$  concentrations. Their stability constant for this complex ( $10^{2.13}$ ) is sufficiently small compared to that for the 1:1 complex ( $10^{5.83}$ ) that stepwise formation is predicted. Solubility limitations unfortunately prevented the extension of our n.m.r. measurements to sufficiently high  $Mg^{2+}$  concentrations to test for a second change of slope in the  $P^{31}$  n.m.r. data above 2.0 moles of metal. The effects of complexing on the spin coupling constant for tripolyphosphate give additional indication of 2:1 complexing for  $Mg^{2+}$ , however.

**B. Tripolyphosphate Spin Coupling.** The apparent phosphorus-phosphorus spin coupling constant for  $P_3O_{10}^{5-}$ ,  $J_{pp}$ , is really an average over all the dynamic ionic species which are simultaneously present. Its value decreased from 21.7 to 15.3 c.p.s. with increasing  $Mg^{2+}$  complexing. The data are given in Table I. After formation of the  $MgP_3O_{10}^{3-}$  complex, the second equivalent of  $Mg^{2+}$  produces relatively less effect on the value of  $J_{pp}$ , although it continues to decrease as the  $Mg_2P_3O_{10}^{3-}$  complex is formed. With  $Ca^{2+}$ , for which no 2:1 complex has been reported, the value of  $J_{pp}$  levels off at about 17.3 c.p.s. after the formation of the  $CaP_3O_{10}^{3-}$  complex.

(15) L. Rogers and C. Reynolds, *ibid.*, **71**, 2081 (1949).

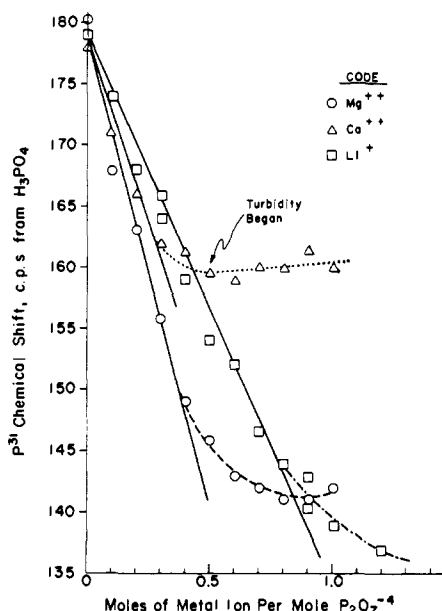

Figure 3. The effect of metal ion complexing on the  $P^{31}$  chemical shift of the pyrophosphate anion at  $\text{pH} \sim 10$  (total pyrophosphate concentration is  $0.17 M$  for  $\text{Mg}^{2+}$  and  $\text{Ca}^{2+}$  and  $0.10 M$  for  $\text{Li}^+$ ).

The limiting value of  $J_{pp}$  in the presence of excess metal ion was also measured with a series of monovalent cations to confirm that the coupling constants decreased in the known order of increasing stability of the complex ions. The data are reported in Table II. It would appear that even with the large  $(\text{CH}_3)_4\text{N}^+$

Table I.  $J_{pp}$  for  $\text{P}_3\text{O}_{10}^{5-}$  in the Presence of  $\text{Mg}^{2+}$  and  $\text{Ca}^{2+}$  Ions<sup>a</sup>

$[\text{M}^{2+}]/[\text{P}_3\text{O}_{10}^{5-}]$	$\text{Mg}^{2+}$	$\text{Ca}^{2+}$
0.00	21.7	21.4
0.20	19.7	20.8
0.40	18.6	19.3
0.60	17.4	17.8
0.80	16.2	17.3
1.00	16.0	17.3
1.20	15.9	17.1
1.40	15.5	17.3
1.60	15.3	... <sup>b</sup>
1.80	... <sup>b</sup>	17.3

<sup>a</sup> Values of  $J_{pp}$  are in c.p.s. <sup>b</sup> Precipitated before measurement.

Table II. Phosphorus Coupling Constants for  $\text{P}_3\text{O}_{10}^{5-}$  with Various Monovalent Cations<sup>a</sup>

Cation	$J_{pp}$ , c.p.s.
$(\text{C}_3\text{H}_7)_4\text{N}^+$	23.6
$(\text{C}_2\text{H}_5)_4\text{N}^+$	23.2
$(\text{CH}_3)_4\text{N}^+$	22.6
$\text{K}^+$	20.4
$\text{Na}^+$	18.8
$\text{Li}^+$	17.3

<sup>a</sup> Solution made by neutralizing cold  $0.5 M$   $\text{H}_5\text{P}_3\text{O}_{10}$  solutions with the respective metal hydroxide to  $\text{pH} 9$ .

cation, there is evidence of some interaction since the apparent value of  $J_{pp}$  increases in the presence of the three tetraalkylammonium cations as one goes from methyl to propyl alkyl groups. The effect is real, but small, so that the usual assumption of noncomplexing by tetramethylammonium ion, which has been frequently made, is thus apparently not completely valid,

although it is certainly better as a first approximation than ignoring the interaction of alkali metal ions.

**C. Pyrophosphate.** Pyrophosphate provided fewer observations than tripolyphosphate because its spectrum consists of only a single peak. Spin coupling between the two magnetically equivalent phosphorus nuclei is not directly measurable, so all information comes from data on change in chemical shift with addition of metal ions. The results are shown in Figure 3.

Good data were obtainable over a smaller range of metal ion to pyrophosphate ratios than for the tripolyphosphate studies since it was much more difficult to obtain homogeneous, supersaturated solutions of pyrophosphate in the presence of  $\text{Mg}^{2+}$  or  $\text{Ca}^{2+}$ . Irreversible precipitation usually began by 1:1 mole ratios of both alkaline earth metal ions. With  $\text{Ca}^{2+}$ , a faint turbidity began by an added calcium ion to pyrophosphate ratio of 0.6. Although the solutions were apparently homogeneous to visual observation, the n.m.r. data level off for  $\text{Ca}^{2+}$  beyond that ratio, suggesting that a very finely dispersed colloidal solid phase may have been formed, rather than true solution. The ability of calcium polyphosphates to form such heterogeneous suspensions is known.<sup>2</sup>

With both  $\text{Mg}^{2+}$  and  $\text{Li}^+$ , the effect of the metal ion at the 1:1 ratio was to shift the  $P^{31}$  resonance to lower field by about 40 c.p.s., or 1.6 p.p.m. This is greater than the effect produced with the end phosphorus nuclei of the  $\text{P}_3\text{O}_{10}^{5-}$  anion but less than the effect produced on the middle phosphorus nucleus of that anion.

**D. Ring Phosphates.** All the phosphorus atoms of trimetaphosphate,  $\text{P}_3\text{O}_9^{3-}$ , are magnetically equivalent, as are those of the tetrametaphosphate ion,  $\text{P}_4\text{O}_{12}^{3-}$ , which exhibits a slightly larger chemical shift. Dissociation constants for 1:1 complexes of  $\text{Mg}^{2+}$  and  $\text{Ca}^{2+}$  with ring phosphates are known.<sup>2</sup> In each case, the complexes with the tetrametaphosphate ring are approximately 100-fold stronger than with the trimetaphosphate ring ( $\text{p}K = 5.2$  to  $5.4$  vs.  $3.3$  to  $3.4$ ).<sup>2</sup> However, the effects of the added ions on the  $P^{31}$  n.m.r. spectra of the respective ring phosphates are nearly identical (see Figure 4). Both  $\text{Li}^+$  and  $\text{Ca}^{2+}$  have little effect on the  $P^{31}$  chemical shifts, but  $\text{Mg}^{2+}$  produces a definite shift to higher field by about 13 to 14 c.p.s. (0.45 p.p.m.) in each case. This shift corresponds to increased shielding of the  $P^{31}$  nuclei, whereas with chain phosphates the effect was opposite; *i.e.*, a deshielding was observed upon formation of the metal-polyphosphate complex. Possible significance of this difference is treated in the Discussion.

**E. Phosphonate Polyions.** An attempt was made to study complexing in several phosphonate polyions such as methylenediphosphonate ( $\text{O}_3\text{P}-\text{CH}_2-\text{PO}_3$ )<sup>4-</sup> and related compounds, which form complexes comparable to pyrophosphate with metal ions. The results were disappointing since only very small changes in  $P^{31}$  chemical shift were detected. We conclude that the inherent asymmetry of the nearest neighbor environments around P in the polyphosphonates as compared to polyphosphates makes the shielding in the former compounds much less sensitive to the small additional perturbations produced by cation complexing.

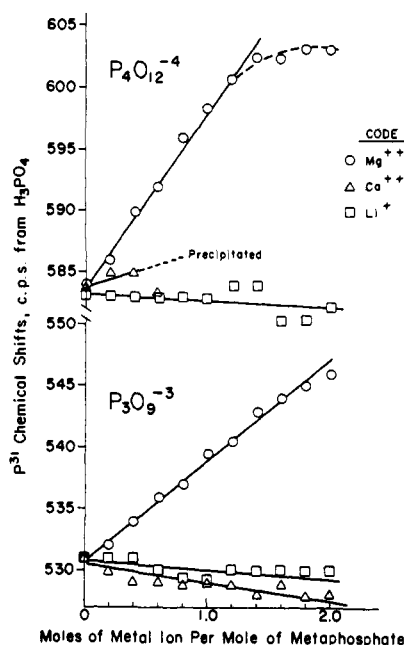

Figure 4. The effect of metal ion complexing on  $P^{31}$  chemical shifts of trimetaphosphate (0.11  $M$ ) and tetrametaphosphate (0.06  $M$ ) at  $pH \sim 7$ .

### Discussion

Assume that the geometry of chain polyphosphate anions may be approximated by a series of collinear tangent Bjerrum-type spheres of radius  $R$  corresponding to some kind of average, effective, unhydrated size for each of the rotatable  $PO_4$  tetrahedra making up the chain anion. For tripolyphosphate, the model may be oriented in cylindrical coordinates ( $\rho, \theta, z$ ) with the origin at the center of the middle phosphorus atom as shown in Figure 5. We will refer to this as the "String-of-Beads" model.

In a time-averaged picture, the five negative anionic charges may be assumed, as limiting cases, to be unpolarizable and uniformly distributed over the surface of each sphere in either a  $-2, -1, -2$  localized arrangement or a delocalized  $-5/3, -5/3, -5/3$  distribution. Chain conformations other than linear are, of course, also possible but need not be considered here since they do not change the qualitative idea to be presented.

Now, let spherical cations of charge  $+n$  and radius  $r$  approach by coulombic attraction to within a distance of closest approach  $R + r$  from the center of any one or more of these negatively charged phosphate spheres of influence. If one evaluates the simple electrostatic potential energy of the cation at its distance of closest approach along the  $\rho$ -coordinate (averaged over all  $\theta$ ) as a function of position along the  $z$ -axis of the anion, then potential energy minima will be seen to exist at  $\pm R$  along the  $z$ -direction. The relative shape of these potential energy wells will depend largely on the effective radii  $r$  and  $R$  of the cation and anion, respectively.

The family of potential energy profiles in Figure 6 was calculated for relative values of  $r/R$  from 0 to 2 according to the simplest equation

$$E = \frac{1}{2}q \sum_i \frac{Q_i}{Dd_i} \quad (1)$$

where  $E$  is the potential energy of a charge  $q$  in the potential field due to charges  $Q_i$  at distances  $d_i$  from

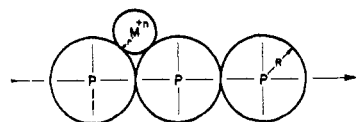

Figure 5. String-of-Beads model for tripolyphosphate.

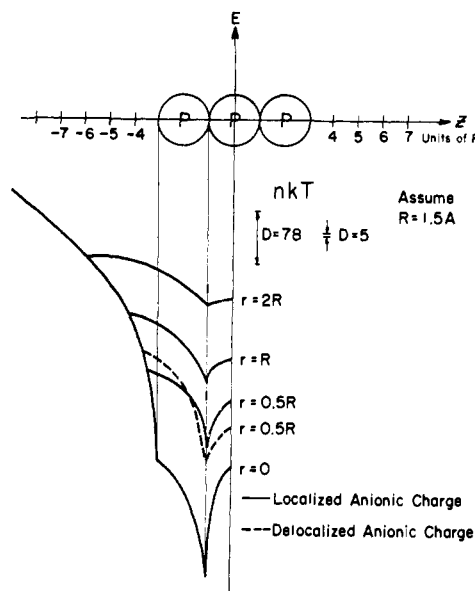

Figure 6. Calculated minimum electrostatic potential energy curves for a cation of effective radius  $r$  and charge  $+n$  in the potential field of a tripolyphosphate anion as predicted by the String-of-Beads model.

$q$  where  $D$  is the effective dielectric constant of the medium. The effect of localized or delocalized anionic charge as defined above is seen from Figure 6 to be much less important to the qualitative picture than the relative sizes of  $r$  and  $R$ .

Now in terms of such a model, the existence of electrostatic ion binding at specific sites along the  $z$ -direction has strict meaning only if the height of the barrier between the potential energy wells at  $z = \pm R$  along the chain is greater than the thermal energy  $kT$ . In estimating the depth of these wells in units of  $kT$ , it is necessary to make an assumption about the appropriate value of the dielectric constant of the medium. There is some reason to believe that the macroscopic dielectric constant of the solvent water may not be entirely appropriate in such calculations. For example, the value of the dielectric constant in the vicinity of polyelectrolytes has been estimated<sup>16</sup> to be as low as 5.

Assuming  $R = 1.5 \text{ \AA}$ , the average length of a P-O bond, the calculated height of the potential barrier between  $z = \pm R$ , in units of  $kT$  at  $25^\circ$ , varies from about 70 for  $r = 0.5R$  and unit dielectric constant to 0.1 for  $r = 2R$  and  $D = 78$ .<sup>17</sup>

The simple model presented above predicts that specific site binding of cations to tripolyphosphate anion by simple electrostatic attraction is reasonable energetically if the hydrated ions lose sufficient water of solvation to permit close approach of anion and cation at something like naked ionic radii where the effective dielectric constant might be considerably less

(16) S. A. Rice and M. Nagasawa, "Polyelectrolyte Solutions," Academic Press Inc., New York, N. Y., 1961, pp. 223, 224, 318.

(17) Assuming a monovalent cation. These values would double for divalent cations.

than the macroscopic dielectric constant of the water solvent. There is some independent evidence tending to support the expulsion of at least some of the waters of hydration in these complexes.<sup>5</sup>

On the other hand, the presence of one or more hydration layers separating complexed cation and anion could be sufficient to eliminate the possibility of this kind of site binding, both by increasing the effective radius  $r$  and by increasing the magnitude of the effective dielectric constant toward that of the macroscopic medium.

Our model is obviously oversimplified and therefore cannot predict accurate quantitative numbers. At worst, it provides a minimum working definition of the concept "specific site binding" as applied to the dynamic, short-lived, electrostatic association of cation-polyanion pairs and in this sense provides a more meaningful representation than conventional structural formulas such as

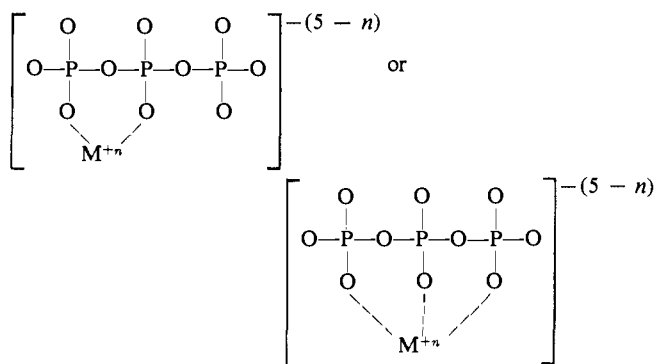

which have occasionally been invoked to describe site binding of metal ions in this system. At best, it provides a qualitative prediction that small unsolvated cations might approach close enough to be electrostatically site bound, but large cations or cations still insulated by a complete hydration shell could not. The crucial question then concerns how closely the complexed ions are actually held and what can be learned about this from the present study.

Our n.m.r. data show that complexed cations such as  $Mg^{2+}$ ,  $Ca^{2+}$ , and  $Li^+$  approach complexing polyphosphate anions sufficiently close so that the magnetic shielding of the phosphorus nuclei is significantly affected. But how close is this? The present state of theory is such that the observed changes in shift cannot be rigorously related to a distance of approach of the ions.

The changes in  $P^{31}$  shifts do not necessarily prove any significant covalent bonding exists between cation and anion since the close approach of a charged metal ion with its associated electric field might simply distort the electronic charge distribution of the intact anion sufficiently to alter the nuclear shielding.

The observed changes in chemical shifts were in certain cases positive, in other cases negative, and in still other cases negligible. Such behavior can be more easily understood in terms of distorted electron charge distributions of the anions than in terms of metal to oxygen bond formation. *The latter effect might be more reasonably expected to produce unidirectional changes in shift for P nuclei in similar en-*

*vironments.* For example, the observation that  $Mg^{2+}$  complexing causes downfield shifts for the middle P atom of chain phosphates and upfield shifts for the corresponding P atoms in ring phosphates can be rationalized on the basis of the String-of-Beads model presented earlier. Remember that the time scale of the n.m.r. measurements is such that the  $P^{31}$  nuclei experience only the time-average structure of the dynamic 1:1 complexes as the metal ion occupies a rapidly changing position at the minima of whatever electrostatic potential wells may be available to it. For chain phosphates, these wells will lie along the side of the polyanion, while for the ring phosphates they must lie centered above and below the plane of the ring.

If we consider the distortion of the electronic environment around P by the proximity of a metal ion to be approximated by a shift in the center of anionic electron density toward the cation with respect to the P nucleus, then the different geometry of the chain vs. ring phosphate complexes should compel them to be affected in opposite ways. The effect with chain phosphates would be a constant outward polarization of electronic charge tending to deshield the P nuclei, while with the ring phosphates, the net, time-averaged effect would be a resultant inward attraction of electronic charge toward the center of the ring and the P nuclei, with presumably an opposite effect.

An additional point is that in the case of tripolyphosphate, the middle P nucleus was always found to be more greatly affected than the end P nuclei. Occupation of specific sites between end and middle phosphate groups by a complexed cation would, in a 1:1 complex, place the cation adjacent to the middle phosphate group at all times but adjacent to a given end phosphate group only 50% of the time on a statistical basis. Thus, a greater effect on the central P nucleus is to be expected, other things being equal. The absolute magnitude of the observed changes in chemical shifts with increasing  $[M^{n+}]/[P_3O_{10}^{5-}]$  ratio may include small contributions due to accompanying incremental changes in bulk magnetic susceptibility. Bulk susceptibility effects, however, cannot account for (a) changes in spin coupling constants which are field independent, (b) changes in relative shift between nonidentical nuclei in the same sample, or (c) the unique events at the 1:1 mole ratio. These effects must arise from specific interactions between the metal cations and the polyphosphate anion.

## Summary

$P^{31}$  n.m.r. measurements provide a sensitive detector for the interaction of phosphate polyanions and complexed alkali metal or alkaline earth cations. In the absence of a sufficiently detailed theory of  $P^{31}$  chemical shifts, such measurements cannot be rigorously interpreted at present. The observations can be rationalized, however, in terms of a simple model of electrostatic binding of cations to the anion at fixed sites which are subject to time-averaging in at least one dimension.

*Acknowledgment.* The assistance of Mr. George F. Brautigam with some of the experimental measurements is gratefully acknowledged.